

FITNESS	PISTON	LEST	RICARICA	R-PRO	INOX	STREET WORKOUT
STATION FUSION	SALUTE	COMBATTENTE	NINJA	FIGHT CLUB	SENIOR	ARREDO URBANO

MULTI PRESS



Scansiona



UNA VERA MACCHINA DA ALLENAMENTO!

La Multi Press è un attrezzo della nostra gamma a pistoni. Fa lavorare i muscoli pettorali, i tricipiti e le spalle.

Siediti sul sedile, afferra le maniglie davanti a te e spingile. Poi tornate delicatamente alla posizione di partenza.

Regola la manopola per aumentare o diminuire la resistenza.

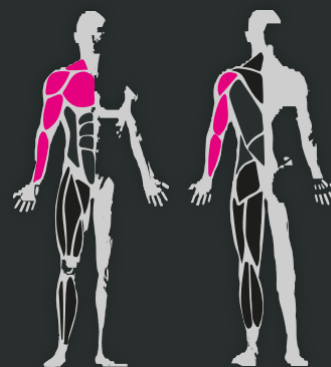

DIMENSIONI

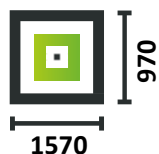

COACHING
PERSONALIZZATO

DISPONIBILE SUI
Google play



Télécharger dans
l'App Store



10 **GARANZIA***
ANNI



05 24 84 77 27



CONTACT@FREETNESS.FR



WWW.FREETNESS.FR



I COMPONENTI

1 Attrezzo realizzato interamente in acciaio zincato e successivamente verniciato a polvere.

2 Il piano di formazione, fissato al telaio e tradotto in 4 lingue per 4 profili sportivi.

3 Pistone idraulico in acciaio inox con resistenza regolabile (8 livelli).

4 Montaggio su pinto con sgabello di ancoraggio. Copertura in acciaio.

Su che tipo di suolo può essere installato?

Cemento, rivestito e stabilizzato



Terreno soffice



Terreno erboso



Truciolini di legno*



Ghiaia*



Sabbia*



Pavimentazione soffice*



Lastra ammortizzante*



Erba sintetica*



*secondo la norma EN 16630

ZONA D'IMPATTO

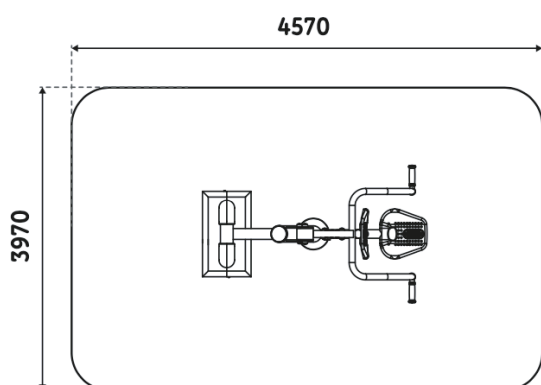

SIGILLATURA FONDAZIONE

Sgabello di ancoraggio

