

FITNESS	PISTON	<b>LEST</b>	RICARICA	R-PRO	INOX	STREET WORKOUT
STATION FUSION	SALUTE	COMBATTENTE	NINJA	FIGHT CLUB	SENIOR	ARREDO URBANO

## STANDING LEST LOW ROW MACHINE

### 3 LIVELLI DI CARICO!



### PER SVILUPPARE GLI ARTI SUPERIORI!

Posizionarsi sull'attrezzo, regolare i pesi in base alla forza desiderata (3 posizioni possibili).

Eeguire le serie secondo il proprio piano di allenamento!

La gamma di attrezzi LEST deve essere installata preferibilmente in uno spazio supervisionato da professionisti.

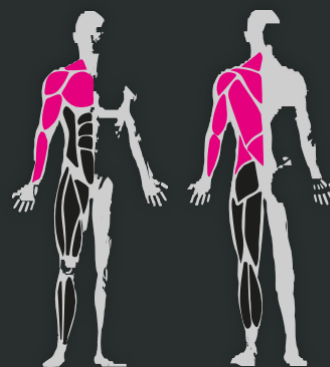

#### DIMENSIONI

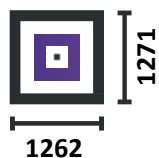

**COACHING**  
**P**ERSONALIZZATO



**10** **GARANZIA\***  
**ANNI**

## I COMPONENTI

- 1** Struttura in acciaio zincato e verniciato a polvere.
- 2** Sistema di regolazione del carico sulle guide. Fermi interni inaccessibili.
- 3** Programma di allenamento in acciaio inox rivettato sull'attrezzo.
- 4** Sedili in HDPE (polietilene ad alta densità).

Su che tipo di suolo può essere installato?

Cemento, rivestito e stabilizzato



Terreno soffice



Terreno erboso



Truciolini di legno\*



Ghiaia\*



Sabbia\*



Pavimentazione soffice\*



Lastra ammortizzante\*



Erba sintetica\*



\*secondo la norma EN 16630

### ZONA D'IMPATTO

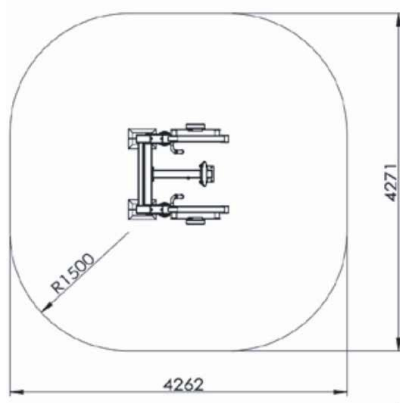

### FONDAZIONE DI ANCORAGGIO

