

FITNESS	PISTON	LEST	RICARICA	R-PRO	INOX	STREET WORKOUT
STATION FUSION	SALUTE	COMBATTENTE	NINJA	FIGHT CLUB	SENIOR	ARREDO URBANO

TRIPLA TRAVE



UN PERCORSO COLLEGATO!

Migliorare l'agilità, la velocità e la forza con il Percorso Ninja. Collegarsi all'App gratuita Freetness per confrontare e registrare il proprio record!

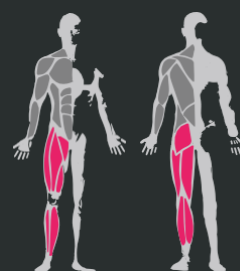

DIMENSIONI

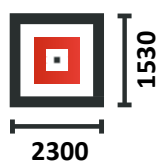

COACHING
PERSONALIZZATO



10 **GARANZIA***
ANNI

IL PERCORSO NINJA

PARTE DI UN PERCORSO COMPLETO CHE PERMETTE DI PARTECIPARE AD UN CONCORSO ONLINE (VEDI SOTTO)!

UN CONCETTO ABBINATO ALL'APPLICAZIONE FREETNESS

UTILIZZANDO LA NOSTRA APPLICAZIONE MOBILE, L'UTENTE SCOPRE IL CONCETTO DI FREETNESS NINJA.

UNA VOLTA CONSULTATE LE REGOLE DEL GIOCO, È POSSIBILE FILMARE LA PROPRIA PERFORMANCE E REGISTRARE IL PROPRIO RECORD.

IL VIDEO SARÀ POI CONTROLLATO DAI NOSTRI TECNICI, QUINDI PUBBLICATO E VISIBILE A TUTTI GLI ALTRI NINJA !

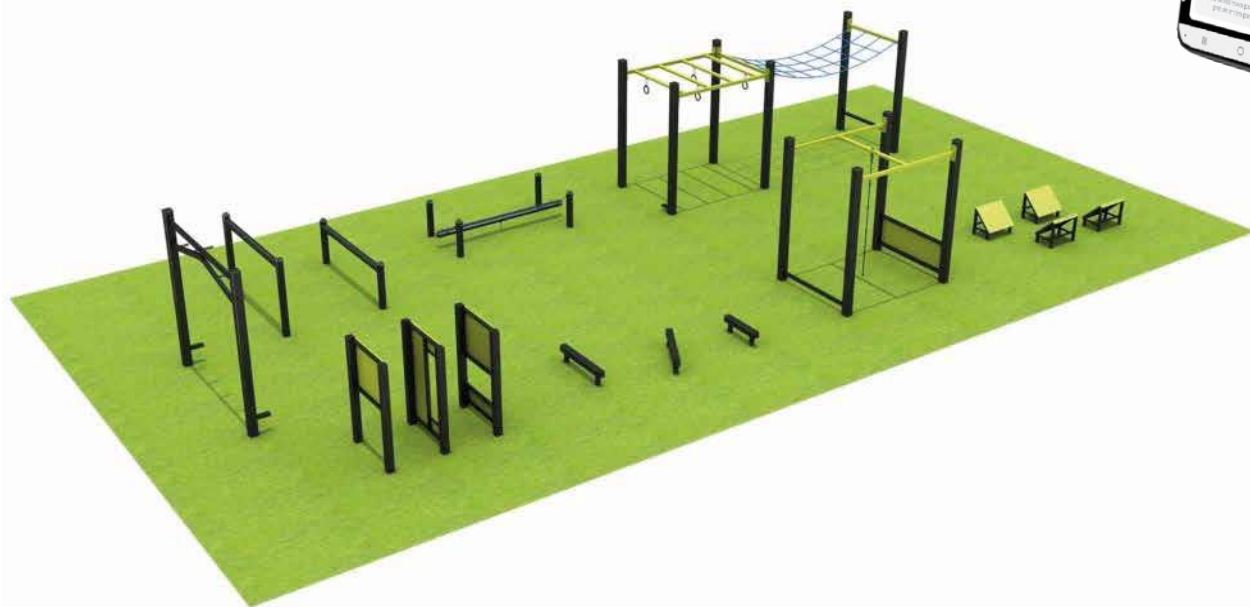
CREARE UN PERCORSO NINJA COMPLETO !

OVUNQUE VENGA INSTALLATO, IL PERCORSO È COMPOSTO DAGLI STESSI ELEMENTI, DISPOSTI ESATTAMENTE ALLA STESSA DISTANZA L'UNO DALL'ALTRO.

IN QUESTO MODO, LE PRESTAZIONI DEI NINJA POSSONO ESSERE CONFRONTATE ANCHE SE NON SI ESERCITANO NELLO STESSO LUOGO!



I COMPONENTI

1 Struttura in acciaio zincato e verniciato a polvere.

Su che tipo di suolo può essere installato?

Cemento, rivestito e stabilizzato



Terreno soffice



Terreno erboso



Truciolini di legno*



Ghiaia*



Sabbia*



Pavimentazione soffice*



Lastra ammortizzante*



Erba sintetica*

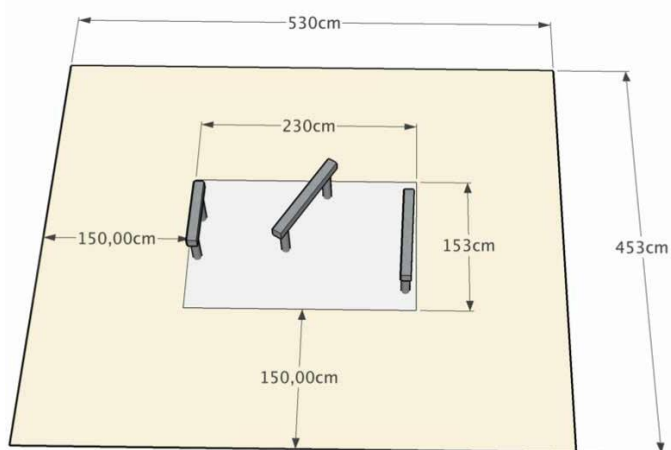

*secondo la norma EN 16630

ZONA D'IMPATTO

1

SIGILLATURA
FONDAZIONI

Annegato direttamente in un plinto in calcestruzzo

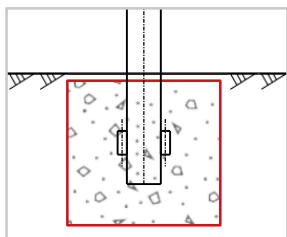
FONDAZIONE
DI ANCORAGGIO

Con tasselli di espansione (opzionale)

